

QUEEN

Bilancia elettronica

Electronic weighing machine



QUEEN bassa



QUEEN alta



RETAIL SOLUTIONS

QUEEN

Bilancia elettronica Electronic weighing machine



3I RETAIL SOLUTIONS			
VIA M. SENA, 27 MADDALONI CE			
TEL. 0823-200130-432556			
17-OTT-12	15:20	BIL. 0	
NETTO	PREZZO	IMPORTO	
kg	EURO/kg	EURO	
PERE			
1,718	1,20	2,06	
ARANCE			
1,618	0,80	1,29	
(PT= 0,100)			
VARI			
1,718	1,50	2,58	
VARI			
Pz. 1 x	1,20	1,20	

PEZZI 4		TOTALE 7,13	
OP. 1	N.P. 5		
ARRIVEDERCI E GRAZIE			

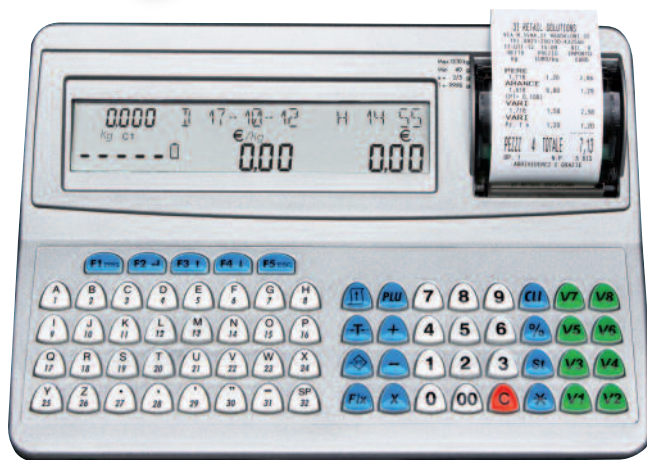

Radio frequenza wireless

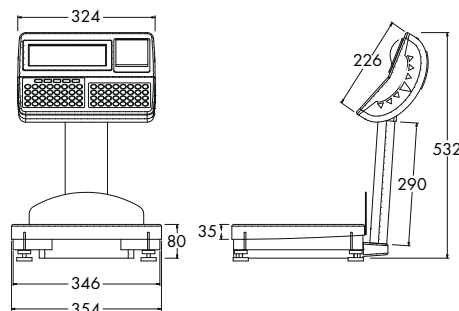

FUNZIONI PRINCIPALI	MAIN FUNCTIONS
DESCRIZIONE	DESCRIPTION
Gestione orologio-datario interno	Automatic clock (date and time)
4/8 operatori	4/8 operators
Intestazione scontrino programmabile	Programmable ticket headings
(5 righe da 26 caratteri)	(5 lines per 26 characters each)
500 PLU (64 diretti da tastiera)	500 PLU (64 direct from keyboard)
Stampante termica grafica 8 dots/mm	Graphic thermal printer 8 dots/mm
Velocità: 70 mm/s	Speed: 70 mm/s
Stampante "Top Quality" con carta Liner-less adesiva in opzione	"Top Quality" printer with Liner-less adhesive paper in option
Larghezza carta 57 mm	Paper width 57 mm
Stampa data di confezione e scadenza	Packaging and best-before date printing
Stampa del codice a barre programmabile EAN13	Programmable Bar code EAN13 printing
Funzione resto	Change function
Riapertura scontrino	Ticket re-opening
Stornata delle transazioni	Transactions void function
Visualizzazione e stampa del sottotale	Partial total display and printing
Variatione rapida prezzi	Quick changing of prices
Tara semiautomatica, manuale, prememorizzata e associata	Semiautomatic, manual, prestored and associated tare
Totale parziale operatori	Operator's partial total
Totale Plu	PLU totals
Display Custom a cristalli liquidi LCD retroilluminato	Display Custom LCD with backlight
Alimentazione esterna 12/24V (optional)	External power supply 12/24V (optional)
Alimentazione da batteria 6V, facilmente sostituibile dall'esterno (autonomia 60 ore)	Power supply from 6V accumulator, easy to substitute from service dep. (autonomy 60 hours)
Rete di bilance (max 6 bilance)	Network of scales (max 6 scales)
Kit radio frequenza wireless	Kit wireless network
Programmazione da PC	Programming by PC
Collegamento con vari registratori di cassa	Electronic Cash Register cooperation
Portate disponibili: 30kg/5g; 12-30kg/2-5g; 12kg/2g; 6kg/1g	Available capacity: 30kg/5g; 12-30kg/2-5g; 12kg/2g; 6kg/1g

M CE Certificato di approvazione CE del sistema di garanzia della qualità della produzione N° I-VA-003
CE Quality certificate no I-VA-003
 Normative e Direttive / Directives: **EN 45501 - EN 55022** (89/336/CEE - 92/31/CEE - 93/68/CEE)
EN 60950 (73/23/CEE - 93/68/CEE)
 Certificati di approvazione CE del tipo: **101-017 - CE type-approval Certificate no 101-017**



RETAILSOLUTIONS

Sede legale: Via M. Sena, 27 - 81024 Maddaloni (CE)
 Sede operativa: Loc. Capitone - 82019 Sant'Agata de' Goti (BN)
 Tel 0823 200130 / 0823 432556 - Fax 0823 205653
 E-mail: info@3iecr.it